



DRG<sup>®</sup> MCP-1 (human) ELISA (EIA-4857)



As of 9 June 2011 rm (Vers. 1.1)

USA: 

**This kit is intended for Research Use Only.**

**Not for use in diagnostic procedures.**

### 1 INTENDED USE

The human MCP-1 ELISA is an enzyme-linked immunosorbent assay for detection of human MCP-1.

### 2 PRINCIPLES OF THE TEST

An anti-human MCP-1 coating antibody is adsorbed onto microwells.

Human MCP-1 present in the sample or standard binds to antibodies adsorbed to the microwells.

A HRP-conjugated anti-human MCP-1 antibody is added and binds to human MCP-1 captured by the first antibody.

Following incubation unbound HRP-conjugated anti-human MCP-1 is removed during a wash step, and substrate solution reactive with HRP is added to the wells.

A coloured product is formed in proportion to the amount of human MCP-1 present in the sample or standard. The reaction is terminated by addition of acid and absorbance is measured at 450 nm. A standard curve is prepared from 7 human MCP-1 standard dilutions and human MCP-1 concentration determined.

### 3 REAGENTS PROVIDED

#### Reagents for human MCP-1 ELISA (96 tests)

- 1 aluminium pouch with a **Microwell Plate coated** with monoclonal antibody to human MCP-1
- 1 vial (100 µL) **HRP-Conjugate** anti-human MCP-1 monoclonal antibody
- 2 vials human MCP-1 **Standard** lyophilized, 2000 pg/mL upon reconstitution
- 1 vial (5 mL) **Assay Buffer Concentrate 20x** (PBS with 1% Tween 20 and 10% BSA)
- 1 bottle (50 mL) **Wash Buffer Concentrate 20x** (PBS with 1% Tween 20)
- 1 vial (15 mL) **Substrate Solution** (tetramethyl-benzidine)
- 1 vial (15 mL) **Stop Solution** (1M Phosphoric acid)
- 1 vial (0.4 mL) **Blue-Dye**
- 1 vial (0.4 mL) **Green-Dye**
- 2 **Adhesive Films**

#### **4 STORAGE INSTRUCTIONS – ELISA KIT**

Store kit reagents between 2°C and 8°C. Immediately after use remaining reagents should be returned to cold storage (2°C to 8°C). Expiry of the kit and reagents is stated on labels.

Expiry of the kit components can only be guaranteed if the components are stored properly, and if, in case of repeated use of one component, this reagent is not contaminated by the first handling.

#### **5 SPECIMEN COLLECTION AND STORAGE INSTRUCTIONS**

Cell culture supernatant, serum, plasma (EDTA, heparin) and amniotic fluid were tested with this assay. Other biological samples might be suitable for use in the assay. Remove serum or plasma from the clot or cells as soon as possible after clotting and separation.

Pay attention to a possible “**Hook Effect**” due to high sample concentrations (see chapter 10).

Samples containing a visible precipitate must be clarified prior to use in the assay. Do not use grossly hemolyzed or lipemic specimens.

Samples should be aliquoted and must be stored frozen at -20°C to avoid loss of bioactive human MCP-1. If samples are to be run within 24 hours, they may be stored at 2°C to 8°C (for sample stability refer to 12).

Avoid repeated freeze-thaw cycles. Prior to assay, the frozen sample should be brought to room temperature slowly and mixed gently.

#### **6 MATERIALS REQUIRED BUT NOT PROVIDED**

5 mL and 10 mL graduated pipettes

5 µL to 1000 µL adjustable single channel micropipettes with disposable tips

50 µL to 300 µL adjustable multichannel micropipette with disposable tips

Multichannel micropipette reservoir

Beakers, flasks, cylinders necessary for preparation of reagents

Device for delivery of wash solution (multichannel wash bottle or automatic wash system)

Microwell strip reader capable of reading at 450 nm (620 nm as optional reference wave length)

Glass-distilled or deionized water

Statistical calculator with program to perform regression analysis

#### **7 PRECAUTIONS FOR USE**

All chemicals should be considered as potentially hazardous. We therefore recommend that this product is handled only by those persons who have been trained in laboratory techniques and that it is used in accordance with the principles of good laboratory practice. Wear suitable protective clothing such as laboratory overalls, safety glasses and gloves. Care should be taken to avoid contact with skin or eyes. In the case of contact with skin or eyes wash immediately with water. See material safety data sheet(s) and/or safety statement(s) for specific advice.

Do not mix or substitute reagents with those from other lots or other sources.

Do not use kit reagents beyond expiration date on label.

Do not expose kit reagents to strong light during storage or incubation.

Do not pipette by mouth.

Do not eat or smoke in areas where kit reagents or samples are handled.

Avoid contact of skin or mucous membranes with kit reagents or specimens.

Rubber or disposable latex gloves should be worn while handling kit reagents or specimens.

Avoid contact of substrate solution with oxidizing agents and metal.

Avoid splashing or generation of aerosols.

In order to avoid microbial contamination or cross-contamination of reagents or specimens which may invalidate the test use disposable pipette tips and/or pipettes.

Use clean, dedicated reagent trays for dispensing the conjugate and substrate reagent.

Exposure to acid inactivates the conjugate.

Glass-distilled water or deionized water must be used for reagent preparation.

Substrate solution must be at room temperature prior to use.

Decontaminate and dispose specimens and all potentially contaminated materials as they could contain infectious agents.

The preferred method of decontamination is autoclaving for a minimum of 1 hour at 121.5°C.

Liquid wastes not containing acid and neutralized waste may be mixed with sodium hypochlorite in volumes such that the final mixture contains 1.0% sodium hypochlorite. Allow 30 minutes for effective decontamination. Liquid waste containing acid must be neutralized prior to the addition of sodium hypochlorite.

## 8 PREPARATION OF REAGENTS

**Buffer Concentrates** should be brought to room temperature and should be diluted before starting the test procedure.

If crystals have formed in the **Buffer Concentrates**, warm them gently until they have completely dissolved.

### 8.1 Wash Buffer (1x)

Pour entire contents (50 mL) of the **Wash Buffer Concentrate** (20x) into a clean 1000 mL graduated cylinder. Bring to final volume of 1000 mL with glass-distilled or deionized water. Mix gently to avoid foaming. The pH of the final solution should adjust to 7.4.

Transfer to a clean wash bottle and store at 2°C to 25°C. Please note that Wash Buffer (1x) is stable for 30 days.

Wash Buffer (1x) may also be prepared as needed according to the following table:

Number of Strips	Wash Buffer Concentrate (20x) (mL)	Distilled Water (mL)
1 - 6	25	475
1 - 12	50	950

### 8.2 Assay Buffer (1x)

Pour the entire contents (5 mL) of the **Assay Buffer Concentrate** (20x) into a clean 100 mL graduated cylinder. Bring to final volume of 100 mL with distilled water. Mix gently to avoid foaming.

Store at 2°C to 8°C. Please note that the Assay Buffer (1x) is stable for 30 days.

Assay Buffer (1x) may also be prepared as needed according to the following table:

Number of Strips	Assay Buffer Concentrate (20x) (mL)	Distilled Water (mL)
1 - 6	2.5	47.5
1 - 12	5.0	95.0

### 8.3 HRP-Conjugate

**Please note that the HRP-Conjugate should be used within 30 minutes after dilution.**

Make a 1:100 dilution of the concentrated **HRP-Conjugate** solution with Assay Buffer (1x) in a clean plastic tube as needed according to the following table:

Number of Strips	HRP-Conjugate (mL)	Assay Buffer (1x) (mL)
1 - 6	0.03	2.97
1 - 12	0.06	5.94

### 8.4 Human MCP-1 Standard

Reconstitute **human MCP-1 standard** by addition of distilled water.

Reconstitution volume is stated on the label of the standard vial. Swirl or mix gently to insure complete and homogeneous solubilisation (concentration of reconstituted standard = 2000 pg/mL).

Allow the reconstituted standard to sit for exactly 10 minutes. Mix well prior to making dilutions.

After usage remaining standard cannot be stored and has to be discarded.

**Standard dilutions** can be prepared directly on the microwell plate (see 10.c) or alternatively in tubes (see 8.4.1).

### 8.4.1 External Standard Dilution

Label 7 tubes, one for each standard point: S1, S2, S3, S4, S5, S6, S7

Then prepare 1:2 serial dilutions for the standard curve as follows:

Pipette 225 µL of Assay Buffer (1x) into each tube.

Pipette 225 µL of reconstituted standard (concentration = 2000 pg/mL) into the first tube, labelled S1, and mix (concentration of standard 1 = 1000 pg/mL).

Pipette 225 µL of this dilution into the second tube, labelled S2, and mix thoroughly before the next transfer.

Repeat serial dilutions 5 more times thus creating the points of the standard curve (see Figure 1).

Assay Buffer (1x) serves as blank.

Figure 1

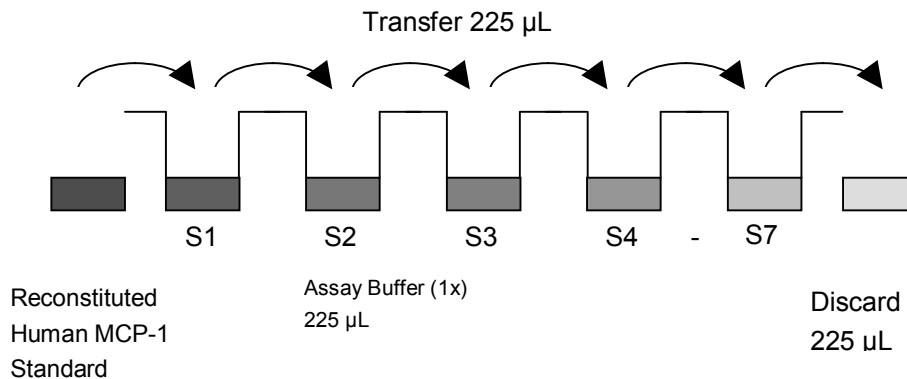

### 8.5 Addition of Colour-giving Reagents: Blue-Dye, Green-Dye

In order to help our customers to avoid any mistakes in pipetting the ELISAs, a tool is offered that helps to monitor the addition of even very small volumes of a solution to the reaction well by giving distinctive colours to each step of the ELISA procedure.

**This procedure is optional**, does not in any way interfere with the test results, and is designed to help the customer with the performance of the test, but can also be omitted, just following the instruction booklet.

Alternatively, the dye solutions from the stocks provided (*Blue-Dye, Green-Dye*) can be added to the reagents according to the following guidelines:

**1. Diluent:** Before standard and sample dilution add the *Blue-Dye* at a dilution of 1:250 (see table below) to the appropriate diluent (1x) according to the test protocol. After addition of *Blue-Dye*, proceed according to the instruction booklet.

5 mL Assay Buffer (1x)	20 µL <i>Blue-Dye</i>
12 mL Assay Buffer (1x)	48 µL <i>Blue-Dye</i>
50 mL Assay Buffer (1x)	200 µL <i>Blue-Dye</i>

**2. HRP-Conjugate:** Before dilution of the concentrated HRP-Conjugate add the *Green-Dye* at a dilution of 1:100 (see table below) to the Assay Buffer (1x) used for the final conjugate dilution. Proceed after addition of *Green-Dye* according to the instruction booklet: Preparation of HRP-Conjugate.

3 mL Assay Buffer (1x)	30 µL <i>Green-Dye</i>
6 mL Assay Buffer (1x)	60 µL <i>Green-Dye</i>

**9 TEST PROTOCOL**

- a. Determine the number of microwell strips required to test the desired number of samples plus appropriate number of wells needed for running blanks and standards. Each sample, standard, blank and optional control sample should be assayed in duplicate. Remove extra microwell strips from holder and store in foil bag with the desiccant provided at 2°C-8°C sealed tightly.
- b. Wash the microwell strips twice with approximately 400 µL **Wash Buffer** per well with thorough aspiration of microwell contents between washes. Allow the Wash Buffer to sit in the wells for about **10 – 15 seconds** before aspiration. Take care not to scratch the surface of the microwells.  
After the last wash step, empty wells and tap microwell strips on absorbent pad or paper towel to remove excess Wash Buffer. Use the microwell strips immediately after washing. Alternatively microwell strips can be placed upside down on a wet absorbent paper for not longer than 15 minutes. **Do not allow wells to dry.**
- c. **Standard dilution on the microwell plate** (Alternatively the standard dilution can be prepared in tubes - see 8.4.1): Add 100 µL of Assay Buffer (1x) in duplicate to all **standard wells**. Pipette 100 µL of prepared **standard** (see Preparation of Standard 8.4, concentration = 2000 pg/mL) in duplicate into well A1 and A2 (see Table 1). Mix the contents of wells A1 and A2 by repeated aspiration and ejection (concentration of standard 1, S1 = 1000 pg/mL), and transfer 100 µL to wells B1 and B2, respectively (see

**DRG**

**DRG<sup>®</sup> MCP-1 (human) ELISA (EIA-4857)**



**As of 9 June 2011 rm (Vers. 1.1)**

**USA: **

Figure 2). Take care not to scratch the inner surface of the microwells. Continue this procedure 5 times, creating two rows of human MCP-1 standard dilutions ranging from 1000 to 16 pg/mL. Discard 100  $\mu$ L of the contents from the last microwells (G1, G2) used.

Figure 2

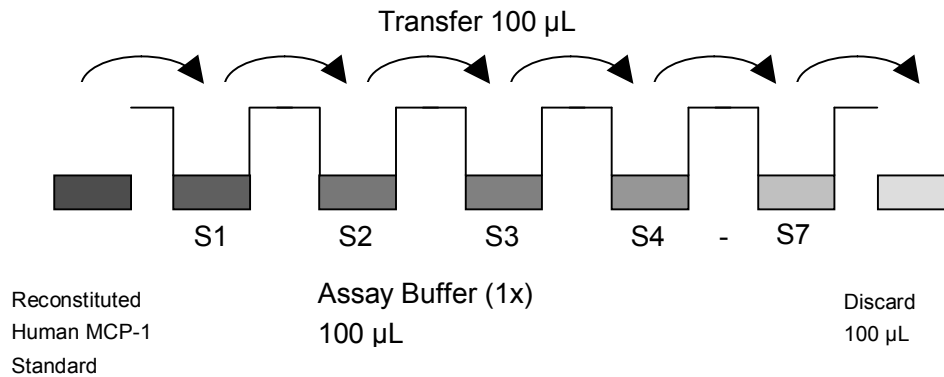

In case of an **external standard dilution** (see 8.4.1), pipette 100 µL of these standard dilutions (S1 - S7) in the standard wells according to Table 1.

Table 1:

Table depicting an example of the arrangement of blanks, standards and samples in the microwell strips:

	1	2	3	4
<b>A</b>	Standard 1 (1000 pg/mL)	Standard 1 (1000 pg/mL)	Sample 1	Sample 1
<b>B</b>	Standard 2 (500 pg/mL)	Standard 2 (500 pg/mL)	Sample 2	Sample 2
<b>C</b>	Standard 3 (250 pg/mL)	Standard 3 (250 pg/mL)	Sample 3	Sample 3
<b>D</b>	Standard 4 (125 pg/mL)	Standard 4 (125 pg/mL)	Sample 4	Sample 4
<b>E</b>	Standard 5 (63 pg/mL)	Standard 5 (63 pg/mL)	Sample 5	Sample 5
<b>F</b>	Standard 6 (31 pg/mL)	Standard 6 (31 pg/mL)	Sample 6	Sample 6
<b>G</b>	Standard 7 (16 pg/mL)	Standard 7 (16 pg/mL)	Sample 7	Sample 7
<b>H</b>	Blank	Blank	Sample 8	Sample 8



- d. Add 100  $\mu$ L of **Assay Buffer (1x)** in duplicate to the **blank wells**.
- e. Add 80  $\mu$ L of **Assay Buffer (1x)** to the **sample wells**.
- f. Add 20  $\mu$ L of each **sample** in duplicate to the **sample wells**.
- g. Prepare **HRP-Conjugate** (see Preparation of HRP-Conjugate 8.3).
- h. Add 50  $\mu$ L of **HRP-Conjugate** to all wells.
- i. Cover with an adhesive film and incubate at room temperature (18°C to 25°C) for 2 hours, if available on a microplate shaker set at 100 rpm.
- j. Remove adhesive film and empty wells. **Wash** microwell strips 3 times according to point b. of the test protocol. Proceed immediately to the next step.
- k. Pipette 100  $\mu$ L of **TMB Substrate Solution** to all wells.
- l. Incubate the microwell strips at room temperature (18°C to 25°C) for about 10 min. Avoid direct exposure to intense light.

**The colour development on the plate should be monitored and the substrate reaction stopped (see next point of this protocol) before positive wells are no longer properly recordable.  
Determination of the ideal time period for colour development has to be done individually for each assay.**

It is recommended to add the stop solution when the highest standard has developed a dark blue colour. Alternatively the colour development can be monitored by the ELISA reader at 620 nm. The substrate reaction should be stopped as soon as Standard 1 has reached an OD of 0.6 – 0.65.

- m. Stop the enzyme reaction by quickly pipetting 100  $\mu$ L of **Stop Solution** into each well. It is important that the Stop Solution is spread quickly and uniformly throughout the microwells to completely inactivate the enzyme. Results must be read immediately after the Stop Solution is added or within one hour if the microwell strips are stored at 2 - 8°C in the dark.
- n. Read absorbance of each microwell on a spectro-photometer using 450 nm as the primary wave length (optionally 620 nm as the reference wave length; 610 nm to 650 nm is acceptable). Blank the plate reader according to the manufacturer's instructions by using the blank wells. Determine the absorbance of both the samples and the standards.

**Note: In case of incubation without shaking the obtained O.D. values may be lower than indicated below. Nevertheless the results are still valid.**

## 10 CALCULATION OF RESULTS

Calculate the average absorbance values for each set of duplicate standards and samples. Duplicates should be within 20 per cent of the mean value.

Create a standard curve by plotting the mean absorbance for each standard concentration on the ordinate against the human MCP-1 concentration on the abscissa. Draw a best fit curve through the points of the graph (a 5-parameter curve fit is recommended).

To determine the concentration of circulating human MCP-1 for each sample, first find the mean absorbance value on the ordinate and extend a horizontal line to the standard curve. At the point of intersection, extend a vertical line to the abscissa and read the corresponding human MCP-1 concentration.

**If instructions in this protocol have been followed samples have been diluted 1:5 (20  $\mu$ L sample + 80  $\mu$ L Assay Buffer (1x)), the concentration read from the standard curve must be multiplied by the dilution factor (x 5).**

**Calculation of samples with a concentration exceeding standard 1 will result in incorrect, low human MCP-1 levels (Hook Effect). Such samples require further external predilution according to expected human MCP-1 values with Assay Buffer (1x) in order to precisely quantitate the actual human MCP-1 level.**

It is suggested that each testing facility establishes a control sample of known human MCP-1 concentration and runs this additional control with each assay. If the values obtained are not within the expected range of the control, the assay results may be invalid.

A representative standard curve is shown in Figure 3. This curve cannot be used to derive test results. Each laboratory must prepare a standard curve for each group of microwell strips assayed.

*Figure 3:*

Representative standard curve for human MCP-1 ELISA. Human MCP-1 was diluted in serial 2-fold steps in Assay Buffer (1x). Do not use this standard curve to derive test results. A standard curve must be run for each group of microwell strips assayed.

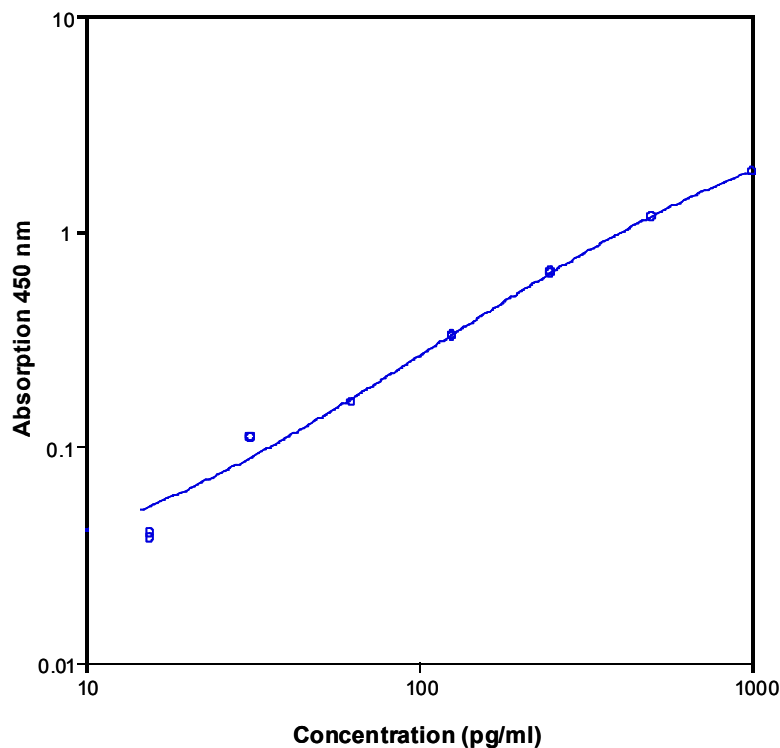

Table 2: Typical data using the human MCP-1 ELISA  
Measuring wavelength: 450 nm, Reference wavelength: 620 nm

Standard	Human MCP-1 Concentration (pg/mL)	O.D. at 450 nm	Mean O.D. at 450 nm	C.V. (%)
1	1000	1.899	1.889	0.8
	1000	1.877		
2	500	1.174	1.174	0.1
	500	1.173		
3	250	0.641	0.640	0.3
	250	0.638		
4	125	0.329	0.327	1.3
	125	0.323		
5	63	0.159	0.161	0.9
	63	0.161		
6	31	0.109	0.111	1.3
	31	0.111		
7	16	0.038	0.040	3.6
	16	0.040		
Blank	0	0.001	0.003	
	0	0.004		

The OD values of the standard curve may vary according to the conditions of assay performance (e.g. operator, pipetting technique, washing technique or temperature effects). Furthermore shelf life of the kit may affect enzymatic activity and thus colour intensity. Values measured are still valid.

## 11 LIMITATIONS

Since exact conditions may vary from assay to assay, a standard curve must be established for every run.

Bacterial or fungal contamination of either screen samples or reagents or cross-contamination between reagents may cause erroneous results.

Disposable pipette tips, flasks or glassware are preferred, reusable glassware must be washed and thoroughly rinsed of all detergents before use.

Improper or insufficient washing at any stage of the procedure will result in either false positive or false negative results.

Empty wells completely before dispensing fresh wash solution, fill with Wash Buffer as indicated for each wash cycle and do not allow wells to sit uncovered or dry for extended periods.

The use of radioimmunotherapy has significantly increased the number of samples with human anti-mouse IgG antibodies (HAMA). HAMA may interfere with assays utilizing murine monoclonal antibodies leading to both false positive and false negative results. Serum samples containing antibodies to murine immunoglobulins can still be analysed in such assays when murine immunoglobulins (serum, ascitic fluid, or monoclonal antibodies of irrelevant specificity) are added to the sample.

## 12 SAMPLE STABILITY

### 12.1.1 Freeze-Thaw Stability

Aliquots of serum samples (spiked or unspiked) were stored at -20°C and thawed 5 times, and the human MCP-1 levels determined. There was no significant loss of human MCP-1 immunoreactivity detected by freezing and thawing.

### 12.1.2 Storage Stability

Aliquots of serum cell culture supernatant samples (spiked or unspiked) were stored at -20°C, 2-8°C, room temperature (RT) and at 37°C, and the human MCP-1 level determined after 24 h. There was no significant loss of human MCP-1 immunoreactivity detected during storage under above conditions.

## 13 BIBLIOGRAPHY

1. Rollins BJ.1997.Blood 90:909.
2. Baggiolini M., Dewald B. and Moser B.1997.Annu.Rev. Immunol. 15:675.
3. Proost P., Wuyts A. and van Damme J.1996.Int. j. Clin. Lab. Res.26:211.
4. Taub D.D.1996.Cytokine Growth Factor Rev. 7:355.
5. Yoshimura T., Yuhki N., Moore SK., Appella E., Lerman MI., Leonard EJ.1989.FEBS Lett 244:487.
6. Carr MW., Roth SJ., Luther E., Rose SS., Springer TA.1994.Proc Natl Acad Sci USA 91:3652.
7. Taub DD., Proost P., Murphy WJ., Anver M., Longo DL., van Damme J., Oppenheim JJ.1995. J.Clin.Inverst. 95:1370.
8. Shyy YJ., Li YS., Kolattukudy PE.1990. Biochem Biophys Res Commun 169:346.
9. Namiki M., Kawashima S., Yamashita T., Ozaki M., Hirase T., Ishida T., Inoue N., Hirata K., Matsukawa A., Morishita R., Kaneda Y., Yokoyama M.2002.Arterioscler Thromb Vasc Biol. 22:115.

10. Graves DT., Jiang Y., Valente AJ.1999.Front Biosci. 4:D571.
11. Grammas P., Ovase R.2001.Neurobiol Aging. 22:837.
12. Tarzami ST., Cheng R., Miao W., Kitsis RN., Berman JW.2002. J Mol Cell Cardiol. 34:209.
13. Mateo L., La Linn M., McColl SR., Cross S., Gardner J., Suhrbier A.2000.Intervirolology. 43:55.
14. Edwards JA., Denis F., Talbot PJ.2000.J Neuroimmunol. 108:73.
15. McManus C., Berman JW., Berett FM., Staunton H., Farrell M., Brosnan CF.1998.J Neuroimmunol. 86:20.
16. Mahad DJ., Howell SJ., Woodroffe MN.2002.J Neurol Neurosurg Psychiatry. 72:498.
17. Kuna P., Reddigari SR., Rucinski D., Oppenheim JJ., Kaplan AP.1992. J Exp Med 175:489

**14 REAGENT PREPARATION SUMMARY**

**14.1 Wash Buffer (1x)**

Add **Wash Buffer Concentrate** 20x (50 mL) to 950 mL distilled water.

Number of Strips	Wash Buffer Concentrate (mL)	Distilled Water (mL)
1 - 6	25	475
1 - 12	50	950

**14.2 Assay Buffer (1x)**

Add **Assay Buffer Concentrate** 20x (5 mL) to 95 mL distilled water.

Number of Strips	Assay Buffer Concentrate (mL)	Distilled Water (mL)
1 - 6	2.5	47.5
1 - 12	5.0	95.0

**14.3 HRP-Conjugate**

Make a 1:100 dilution of **HRP-Conjugate** in Assay Buffer (1x):

Number of Strips	HRP-Conjugate (mL)	Assay Buffer (1x) (mL)
1 - 6	0.03	2.97
1 - 12	0.06	5.94

**14.4 Human MCP-1 Standard**

Reconstitute lyophilized **human MCP-1 standard** with distilled water. (Reconstitution volume is stated on the label of the standard vial.)



As of 9 June 2011 rm (Vers. 1.1)

USA: 

## 15 TEST PROTOCOL SUMMARY

1. Determine the number of microwell strips required.
2. Wash microwell strips twice with Wash Buffer.
3. Standard dilution on the microwell plate: Add 100 µL Assay Buffer (1x), in duplicate, to all standard wells. Pipette 100 µL prepared standard into the first wells and create standard dilutions by transferring 100 µL from well to well. Discard 100 µL from the last wells.  
Alternatively external standard dilution in tubes (see 8.4.1): Pipette 100 µL of these standard dilutions in the microwell strips.
4. Add 100 µL Assay Buffer (1x), in duplicate, to the blank wells.
5. Add 80 µL Assay Buffer (1x) to sample wells.
6. Add 20 µL sample in duplicate, to designated sample wells.
7. Prepare HRP-Conjugate.
8. Add 50 µL HRP-Conjugate to all wells.
9. Cover microwell strips and incubate 2 hours at room temperature (18°C to 25°C).
10. Empty and wash microwell strips 3 times with Wash Buffer.
11. Add 100 µL of TMB Substrate Solution to all wells.
12. Incubate the microwell strips for about 10 minutes at room temperature (18°C to 25°C).
13. Add 100 µL Stop Solution to all wells.
14. Blank microwell reader and measure colour intensity at 450 nm.

**Note: If instructions in this protocol have been followed samples have been diluted 1:5 (20 µL sample + 80 µL Assay Buffer (1x)), the concentration read from the standard curve must be multiplied by the dilution factor (x 5).**

Version 2008-04-08\_rm